

# CN - CNi Technical Data



# CN - CNI Technical Data

VDI 2198

Specification	1.1	Manufacturer		OM	OM	OM	OM
	1.2	Manufacturer type designation		CN 14	CN 20	CNI 14	CNI 20
	1.3	Drive unit: electric (battery or mains), diesel, petrol, fuel gas		Electric	Electric	Electric	Electric
	1.4	Operator type: hand, pedestrian, standing, seated, order-picker		Pedestrian	Pedestrian	Pedestrian	Pedestrian
	1.5	Load capacity	Q (t)	1,4	2	1,4 (2 <sup>(1)</sup> )	2 (2 <sup>(1)</sup> )
	1.6	Load center	c (mm)	600	600	600	600
	1.8	Load distance, centre of drive axle to fork face	x (mm)	711 (2)	706 (2)	637 (2) (3)	637 (2) (3)
	1.9	Wheelbase	y (mm)	1323	1323	1305 (3) (6)	1359 (3)
	Weights	2.1	Truck weight (without battery)	kg	880 (4)	1010 (4)	975 (4)
2.2		Axle loading, loaded (front/ rear)	kg	888 / 1652 (4)	1054 / 2251 (4)	990 / 1597 (4) (14)	1092 / 2235 (4) (14)
2.3		Axle loading, unloaded (front/ rear)	kg	770 / 369 (4)	894 / 411 (4)	830 / 357 (4) (14)	904 / 423 (4) (14)
Wheels and Tyres	3.1	Tyres: solid rubber, superelastic, pneumatic, polyurethane		Polyurethane	Polyurethane	Polyurethane	Polyurethane
	3.2	Tyre size (front)	mm	230 / 120	230 / 120	230/120	230/120
	3.3	Tyre size (rear)	mm	85 x 90	85 x 70	85 x 70	85 x 70
	3.5	Wheels number, front / rear (x= driven wheels)		1x-1 / 2	1x-1 / 4	1x-1 / 4	1x-1 / 4
	3.6	Tread, front	b10 (mm)	574	574	574	574
	3.7	Tread, rear	b11 (mm)	380	380	380	380
Dimensions and Overall Sizes	4.2	Height, mast lowered	h1 (mm)	2327	2327	2332	2332
	4.3	Free lift	h2 (mm)	140	90	140	90
	4.4	Lift height	h3 (mm)	3580	3580	3580	3580
	4.5	Height, mast extended	h4 (mm)	4066 (5)	4088 (5)	4070 (5)	4092 (5)
	4.6	Initial lift	h5 (mm)	/	/	135	135
	4.9	Height of tiller in drive position min / max	h14 (mm)	762 / 1232	762 / 1232	762 / 1232	762 / 1232
	4.15	Forks height, lowered	h13 (mm)	86	86	91	91
	4.19	Overall length	l1 (mm)	1951	1956	1999	2053
	4.20	Length to face of forks	l2 (mm)	789	794	844 (6)	903
	4.21	Overall width	b1 (mm)	860	860	860	860
	4.22	Fork dimensions	s/e/l (mm)	66 / 190 / 1150	61 / 200 / 1150	66 / 190 / 1150	61 / 200 / 1150
	4.24	Fork carriage width	b3 (mm)	680	680	680	680
	4.25	Maximum forks width	b5 (mm)	570	570	570	570
	4.31	Ground clearance, laden, below mast	m1 (mm)	/	/	/	/
	Performance	4.32	Ground clearance, centre of wheelbase	m2 (mm)	30	30	25 / 160 (3)
4.33		Aisle width for pallets 1000x1200 crossways (1200 forking side)	Ast (mm)	2485 (7)	2487 (7)	2505 (6) (7)	2559 (7)
4.34		Aisle width pallets 800x1200 lengthways (800 forking side)	Ast (mm)	2451 (7)	2455 (7)	2493 (6) (7)	2550 (7)
4.35		Turning radius	Wa (mm)	1619 (7)	1619 (7)	1602 (7) (3)	1655 (7) (3)
5.1		Travel speed: Loaded / unloaded	km/h	5,5 / 6	5 / 6	5,5 / 6	5 / 6
5.2		Lift speed: Loaded / unloaded	m/s	0,16 / 0,26 (8)	0,10 / 0,17	0,16 / 0,26	0,10 / 0,17
5.3		Lowering speed: Loaded / unloaded	m/s	0,40 / 0,36	0,40 / 0,36	0,40 / 0,36	0,30 / 0,23
5.7		Gradeability KB 15': Loaded / unloaded	%	1,4% (4) / 6,7% (4)	0,4% (4) / 5,5% (4)	1,3% (4) / 6,3% (4)	0,3% (4) / 5,3% (4)
5.8		Max gradeability KB 5': Loaded / unloaded	%	4,1% (4) / 9,1% (4) (13)	2,4% (4) / 9,1% (4) (13)	3,9% (4) / 12,2% (4) (12)	2,4% (4) / 10,6% (4) (12)
5.10		Service brake		Electric	Electric	Electric	Electric
Engine	6.1	Drive motor rating S2 60min	kW	1	1	1	1
	6.2	Lift motor rating at S3 15%	kW	2,2 (9) / 3	3	3	3
	6.3	Battery according to British Standard / DIN 43531/35/36 A, B, C		DIN	DIN	DIN 43535 B	DIN 43535 B
	6.4	Battery voltage / nominal capacity k5	V / Ah	24 / 240 (315 - 375)	24 / 315 (375)	24 / 220 (250-330-375)	24 / 330 (375)
	6.5	Battery weight (± 5%)	kg	260 (295 - 304)	295 (304)	212 (220-288-305)	288 (305)
Others	8.1	Control unit type		Electronic	Electronic	Electronic	Electronic
	8.4	Sound level at the driver's ear according to DIN 12 053	dB (A)	< 70	<70	<70	<70

The values presented are to be taken as indicative and not binding: they refer to the standard equipment

(1) Used like transpallet  
 (2) -20 mm with TPX Full free lift mast  
 (3) Value referred in condition with legs extended (h5=135 mm)  
 (4) with DPX LFL mast h3= 3580 & min. nominal battery capacity (see weight, line 6.5)

(5) h4 + 490 mm with load back rest (6) + 52 mm with battery 330 - 375 Ah  
 (7) With tiller active arm in vertical position -45mm  
 (8) Performance obtained with lift motor 3 Kw  
 (9) Value for masts with height till

h3=3580 mm included  
 (10) Mast not available for model CNI (11) + 5 mm for model CNI  
 (12) Max gradeability due to overall dimension 18,3%  
 (13) Max gradeability due to overall dimension 9,1%

(14) Value referred in condition with legs lowered (h5=0 mm)

1 = Marcia  
2 = Frenatura

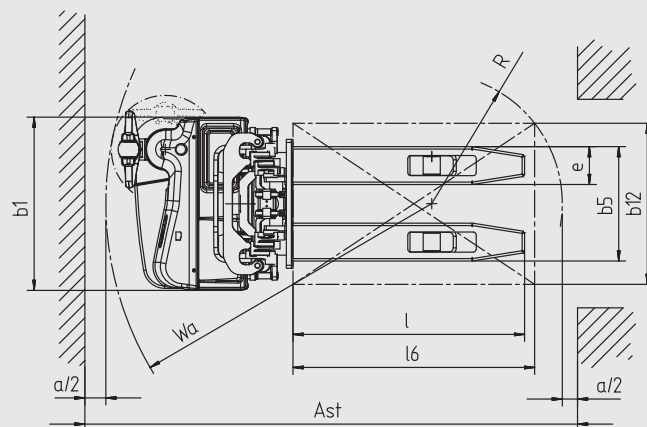
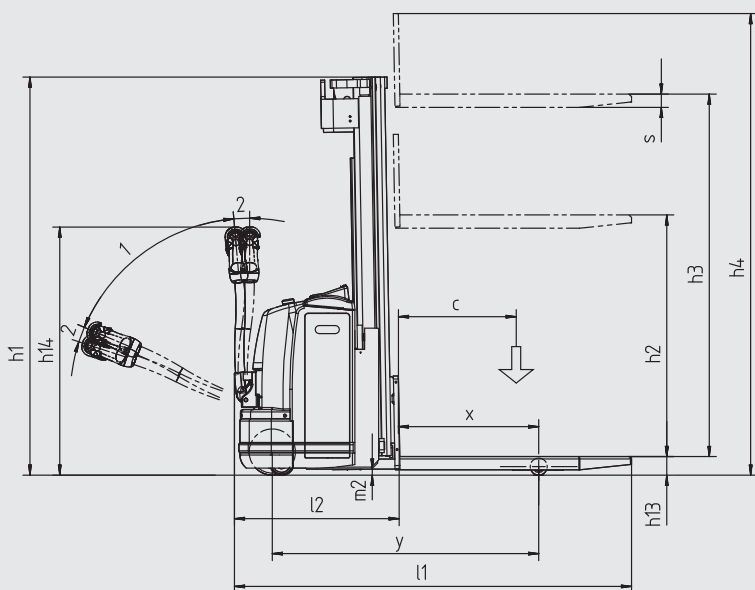

### 1.4 t MAST TYPE CN

		Mono			Simplex				Duplex				Triplex						
Lift height	$h_3$ mm	1510	1660	1810	2480	2900	3280	3580	3980	4480	2590	2990	3300	3600	3870	4170	4470	4940	5390
Height, mast lowered	$h_1$ mm	1977	2132	2282	1777	1977	2177	2327	2527	2777	1777	1977	2177	2327	1777	1877	1977	2177	2327
Height, mast extended	$h_4$ mm	1996	2146	2296	2966	3386	3766	4066	4466	4966	3076	3476	3786	4086	4356	4656	4956	5426	5876
Free lift	$h_2$ mm	1491	1646	1796	140	140	140	140	140	140	1291	1491	1660	1810	1291	1391	1491	1660	1810

### 2.0 t MAST TYPE CN

		Simplex			Duplex				Triplex		
Lift height	$h_3$ mm	2900	3280	3580	2590	2930	3270	3570	4170	4380	
Height, mast lowered	$h_1$ mm	1977	2177	2327	1807	1977	2177	2327	1907	1977	
Height, mast extended	$h_4$ mm	3408	3786	4088	3098	3438	3778	4078	4678	4888	
Free lift	$h_2$ mm	90	90	90	1299	1469	1630	1780	1399	1469	

### 1.4 t MAST TYPE CNI

		Simplex				Duplex			Triplex				
Lift height	$h_3$ mm	2900	3280	3580	3980	4480	2990	3300	3600	4170	4470	4940	5390
Height, mast lowered	$h_1$ mm	1982	2182	2332	2532	2782	1982	2182	2332	1882	1982	2182	2332
Height, mast extended	$h_4$ mm	3391	3771	4071	4471	4971	3481	3791	4091	4661	4961	5431	5881
Free lift	$h_2$ mm	140	140	140	140	140	1491	1660	1810	1391	1491	1660	1810

### 2.0 t MAST TYPE CNI

		Simplex			Duplex			Triplex	
Lift height	$h_3$ mm	2900	3280	3580	2930	3270	3570	4380	
Height, mast lowered	$h_1$ mm	1982	2182	2332	1982	2182	2332	1982	
Height, mast extended	$h_4$ mm	3413	3793	4093	3443	3783	4083	4893	
Free lift	$h_2$ mm	90	90	90	1469	1630	1780	1469	

## CN - CNi Pedestrian Stacker Truck



**The product line:** This line has been specifically designed for intensive stocking operations at medium height, and includes two models with a rated load capacity of 1400 kg and 2000 kg. The CNi version is equipped with initial lift.

**The structure:** ■ The 4-point support with side tiller configuration provides a high degree of stability as well as perfect visibility when loading and unloading at greater heights. ■ The traction unit and castor wheel are completely enclosed within the frame, providing better protection for the operator's feet. ■ The CN and CNi models are available with two types of mast and chassis with a rated load capacity of 1400 kg or 2000 kg ■ The different battery compartments in the two basic models can accommodate a DIN battery in the CNi model and a battery with DIN elements in the CN model. The batteries are completely enclosed within the frame (i.e. they are not visible) and are easily accessed by means of a polyethylene cover. The battery in the CN model can be removed from the side and from the top only in the CNi model. ■ The polyethylene battery covers - made from rotational technology- are very strong and flexible and have the ability to withstand damage without buckling.

**Tiller:** ■ The new one piece tiller made from a very resistant plastic material with an oval-shaped tubular arm that has been robotically welded. ■ The configuration and location of the tiller provides the best working position for operators of all sizes. ■ The lightness of the tiller and the easy controls greatly reduce operator fatigue even during long shifts. When released, the tiller accurately returns to the vertical position without bumping or bouncing and without compromising operator safety. Standard tiller-operated proportional control of the fork lift/lower functions.

**Traction unit:** ■ The separately excited traction motor has a rated power of 1 kW ■ The castor wheel can be easily adjusted to provide excellent grip and stability

**Lift unit:** ■ Masts with a rated load capacity of 1400 kg and 2000 kg ■ Simplex, Duplex and Triplex masts are available (the Simplex mast is not available on the CNi model) with ample visibility and lifting heights up to 5,000 mm ■ Masts with either low free lift (PAL) or high free lift (GAL) are available. ■ Two different lift motors are available (2.2 kW and 3 kW) to meet load capacity and lift height requirements

**Braking:** The truck features two separate braking systems: ■ Service brake ⇒ Inversion braking on the traction motor (regenerative braking) performed by the electronic control when the butterfly direction control is released. ■ Handbrake ⇒ Electromagnetic brake.

**Electronic system:** ■ 24 V DC power. ■ High frequency static electronic control of the traction motor and pump on all models. ■ The hour meter signals any abnormal operation. ■ The new electronic systems ensure low energy consumption and quiet operations. The control system protects the motor and the battery from early wear by preventing high power spikes. ■ The electrical systems and wiring are protected to IP 54 and are waterproof and dustproof, ensuring greater reliability over time. ■ The SAAB terminal connectors are protected to IP 67. ■ Speed reduction when the forks are raised from a predetermined range. ■ Automatic lowering of arms when the fork lift unit is operated (CNi). ■ Lock-out of arm lift function when the forks are raised from a predetermined range (CNi).

Technical data are given as an indication.  
OM Carrelli Elevatori reserves the right to modify them without notice.



OM Carrelli Elevatori S.p.A.  
Viale A. De Gasperi, 7  
I-20020 Lainate (MI)  
Tel.: +39(02)937 65-1  
Fax: +39(02)937 65-450  
www.om-mh.com